

# APPALACHIAN DISTRICT



## KLONDIKE DERBY

**Saturday, January 16, 2010**  
**Hawk Mountain Scout Reservation**

# **2010 KLONDIKE DERBY**

## **HAWK MOUNTAIN COUNCIL**

**Appalachian District**

Dear Scoutmaster & Senior Patrol Leader:

The 2010 Klondike Derby will continue to be a great tradition of winter activities in our district. Your Klondike Derby committee has again proposed an exciting activity, and as in the past, we need your support.

First, please take time to read the attached booklet and become familiar with its contents. There are changes from previous Klondike Derby events. Be aware that some items in the brochure are offered as examples. As long as a patrol follows the guidelines, they will be fine and have a good experience at this event.

Secondly, be aware of the limited role that you and other adults actually have once the Derby begins. This will be a Scout event conducted on a Patrol basis. We need to keep it that way.

Finally, don't be afraid to ask questions prior to the event. It will help make it a better event for everyone involved.

Yours in Scouting,

2010 Klondike Derby Committee

# 2010 KLONDIKE DERBY

## BASIC INFORMATION

**DATE:** Saturday, January 16, 2010. **THE EVENT WILL BE HELD RAIN, SNOW OR SHINE. NO ALTERNATE DATE.** Cancellation, if necessary, will be broadcast by WRFY (102.5 FM) and WEEU (850 AM) by 7:00 AM on Saturday.

**TIME:** 8:00 AM to 4:00 PM

**PLACE:** Hawk Mountain Scout Reservation

**REGISTRATION:** All Units must submit a registration form to the Hawk Mountain, Beaver Family Service Center by Friday, January 8, 2010. Please use the attached form. On the day of the Derby, a Unit Leader must check in at the Administrative Building with a completed Derby Roster listing all Scouts and adults in Camp. All vehicles must remain in the parking lot. **ANY REGISTRATION RECEIVED AFTER THE DEADLINE WILL BE ASSESSED A \$1.00 PER SCOUT LATE FEE.**

**STARTING TIME:** All Patrol Leaders must arrive at camp with their Patrol and sled at 8:00 AM and report to the Boy Scout Dining Hall for their initial inspection. Patrols will be assigned stations when they complete their inspection. **All Patrols and stations will start the trail together at 9:00 AM.** Each station will last 30 minutes. Lunch is one hour. The recognition and awards portion will run from 3:30 – 4:00 PM.

**TEAMS:** Not less than 4 or more than 8 boys. One Scout is to be the driver of the sled (the driver steers and brakes the sled). All other remaining Scouts pull the sled with the tow ropes. The driver must give direction on how to pass obstacles such as logs, rocks, and ditches. All teams must be comprised of Scouts from the same Troop. **NO MORE THAN 8 BOYS MAY BE WITH THE SLED AND PARTICIPATE AT THE KLONDIKE DERBY STATIONS.**

- 
1. Fee for the Derby is \$5.00 per Scout and Scouter. Register by Troop using the attached Registration Form. This fee includes a Klondike Derby patch, a hot dog, hot chocolate and camp costs. Extra patches will be available at \$2.00 each.
  2. Patrol skill recognition streamers and event patches will be given out at the awards portion of the event.
  3. Adult leaders must not be in the station areas, unless assigned, while Patrols are being tested. Failure to comply can cause a loss of points for the Patrol.
  4. Adult leaders are strongly encouraged to help the staff at the Derby stations if asked.
  5. For emergency reasons, we require that a minimum of two adult leaders per Troop (one of whom must be over 21 years of age) remain on the Reservation property during the Derby.
  6. If a Patrol fails to complete the trail, they must sign-out at the inspection sign-in area before leaving the Camp Reservation.
  7. Patrols must follow the trail that is outlined on the map for the event. This map and all scoring instructions for the Derby will be provided to the Patrol Leaders at inspection.
  8. Proper Scout conduct is expected throughout the day. Patrol names must be appropriate, and in good taste.
  9. Class "A" Boy Scout uniform is not recommended for this event.

# 2010 KLONDIKE DERBY

## REQUIRED EQUIPMENT

### PERSONAL EQUIPMENT:

- Mess Kits
- Eating Utensils
- Rain clothing
- Folding pocket knife (no fixed blade knife)
- Cold weather clothing, **gloves and cap**, extra socks in coat pocket (if it is a warm day, above 40 degrees, a long underwear/thermal layer need not be worn but must be brought along. Be Prepared!)
- **Weather – proof shoes or boots.**

### SCOUTS MUST HAVE:

Scouts must have stocking caps or hats that are able to cover the ears, gloves or mittens, and weatherproof shoes or boots. Athletic shoes will not be permitted on the trail. Hoods do not qualify as proper head gear but are recommended as additional protection. **Anyone not properly dressed will not be permitted on the trail!** Judges decision at the initial sled inspection is final!

### PATROL EQUIPMENT:

- Sled made to meet required specifications noted herein
- Patrol Flag
- Patrol cooking gear
- Hobo stove with matches, tinder, kindling and fire wood for lunchtime meal
- Patrol first aid kit (include three pair of rubber gloves and three safety goggles)
- Sled repair kit
- Water jug(s) to hold two gallons of water
- Watch
- Minimum of two compasses
- Rope
- One blanket (at least one full size for making an emergency stretcher)
- Paper and pencils, and a covered clipboard
- Coffee can or plastic container containing a roll of toilet paper

**NOTE:** There will be an initial inspection of Scouts and Patrol gear at the Dining Hall sign-in area before going on the trail and a final inspection along the trail after lunch. All equipment listed above is necessary for the Derby.

***NO BOY SCOUT HANDBOOKS OR OTHER HANDBOOKS, CELL PHONES, OR WALKIE TALKIES ARE PERMITTED ON THE TRAIL. IF ANY OF THESE ITEMS ARE USED, POINTS DEDUCTIONS AND/OR DISQUALIFICATION WILL RESULT.***

# 2010 KLONDIKE DERBY SKILL STATIONS

## **INSPECTION**

Two (2) inspections will be conducted. The first one will be before starting the trail on PATROL and PERSONAL GEAR. The second will be at the end of the trail on the sled, its construction and durability. PROPER ATTIRE MUST BE WORN AT ALL TIMES BY ALL PARTICIPANTS IN THE PATROL (see Personal Equipment).

**COOKING:** Based on proper menu, on-site preparation, leadership, patrol participation, quality of meal, clean-up and good etiquette.

**COMPASS:** Each patrol member will be required to find compass degree readings. They must also know their pace and be able to measure heights and distances.

**FIRST AID:** Will consist of solving and treating an emergency situation that occurs in the woods or along the trail. They will be judged by using the latest edition of the handbook and/or First Aid Merit Badge book.

**KNOTS:** Patrol members should know all of the required knots and other knots found in the Boy Scout Handbook. The Scouts will be required to know how each knot is used.

**WOODS TOOLS:** Patrols must demonstrate the safe use and handling of various woods tools as shown in the Boy Scout Handbook. The choice and effective use of these tools will be stressed.

**MAP READING:** Scouts should be familiar with map symbols, orienting a map, and all other map related topics in the Boy Scout handbook.

**MODEL CAMPSITE:** Scouts will need to find unsafe practices through a mock campsite, and/or questions on camping safety.

**FIRE BUILDING:** Demonstrate basic Boy Scout fire building skills. Know various types of fires and their uses. Each Patrol will participate in a fire building challenge. Tinder, kindling and firewood for this Challenge will be provided at the station. Bring matches.

**BACKPACK:** This station is designed to demonstrate your backpacking skills.

## **SILENT SIGNALS**

## **SURPRISE STATION**

# 2010 KLONDIKE DERBY SLEDS

## SLED SPECIFICATIONS:

Sleds may be of your own design, or you may use the sample plan that is included in this booklet. All sleds must be built to the following specifications:

1. Capable of transporting one Scout and 50 pounds of gear.
2. Length 5 foot minimum; 6 ½ foot maximum.
3. Width – 18 inch minimum; 24 inch maximum.
4. Sleds must have a minimum of 4-inch ground clearance.
5. A pair of wheels on a single axel with a wheel diameter not to exceed eight (8) inches may be mounted on the sled. These wheels must be removable because their usage will be determined at the initial inspection station based on the weather and ground conditions at that time. Wheel size is limited, no deer carts.
6. Sleds are to be made of wood. Metal hardware may be used.
7. Sleds should have two ropes of ¾ inch and 12 feet long; one for each side of the sled (no wash line or twine). A brake rope at the rear of the sled is essential.
8. A sled repair kit with 4 – 5 items is required for minor sled repairs that may be needed on the trail. Include hammer, screwdriver, pliers, wrench, nuts/bolts, nails, or screws and wire/duct tape to repair sled. Inspectors expect each sled to be repairable on the trail, plan your kit accordingly.
9. If commercial skis are used as runners, they must be reinforced with 1" x 4" or heavier boards.
10. Sleds should have wire or cloth on the sides to prevent the loss of Patrol gear.
11. Side rails make lifting of the sled easier over ditches or logs.

## BILL OF MATERIALS

A.	2 pieces	2"x6"x6'6"	runners.
B.	4 pieces	2"x2"x18"	cross supports.
B1.	1 piece	2"x2"x20"	cross support.
C.	4 pieces	1/2"x4"x5'	floor planks.
D.	2 pieces	1"x2"x40"	rear uprights.
E.	2 pieces	1"x2"x31"	second rear upright.
F.	2 pieces	1"x2"x22"	second front upright.
G.	2 pieces	1"x2"x18"	front uprights.
H.	2 pieces	1"x2"x6'	hand rails.
I.	1 piece	1"x4"x16"	tow bar.
J.	1 piece	1"x2"x20"	handle bar.

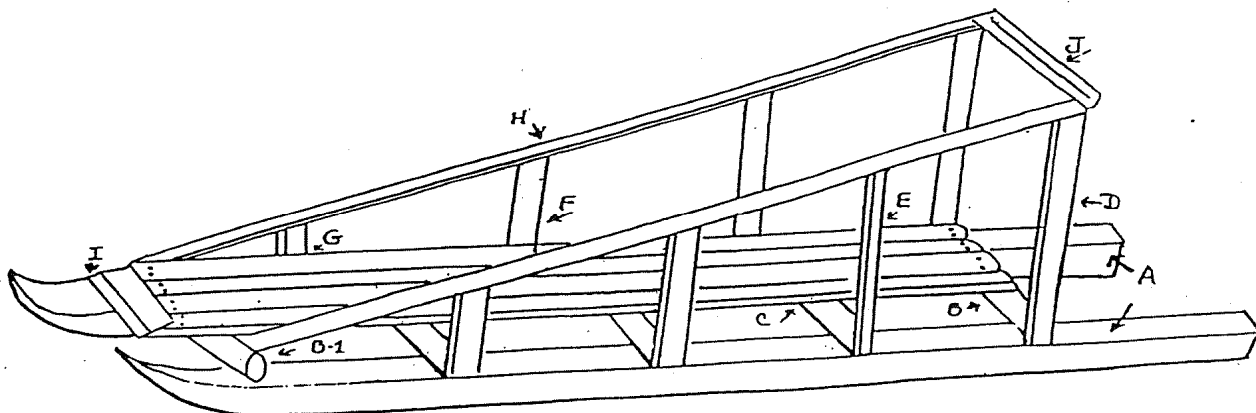

# 2010 KLONDIKE DERBY

## COOKING

**NOTE: LIQUID FUELS ARE NOT PERMITTED AT HAWK MOUNTAIN SCOUT RESERVATION. PROPANE AND BUTANE WILL NOT BE ALLOWED FOR THE COOKING COMPETITION. CHARCOAL MAY BE USED AND IS RECOMMENDED. MATCHLIGHT CHARCOAL IS PREFERRED.**

### COOKING INSTRUCTIONS

Only the Patrol members are permitted to prepare the meal; adults are not permitted to assist in any way. The Patrol is encouraged to prepare additional foods for Troop adults, provided that this does not require additional time. Each Patrol must prepare an extra serving for a judge and a portion of the score will depend on how much the Patrol impresses the judge with their meal. A **Klondike Wooden Spoon Award** will be presented to one Patrol of the Judge's choice at each cooking site.

**MENU:** 1. Meat/Vegetable stew –prepared and cooked on site. No canned or pre-made stew. 2. Hot beverage  
3. Bread, and spread (jelly, peanut butter, butter, etc.) 4. Dessert

The type of meat for the stew and ingredients for the stew will be up to the Patrol. Pre-cooking the meat is allowed and is recommended. Canned vegetables are acceptable to add to a stew.

**UTENSILS:** Each Scout in the Patrol must bring his mess kit and utensils. The Patrol will need a large pot for the stew (a Patrol of 8 will need to prepare 9 servings), a Chef's kit, and additional pots and pans as required. Also two garbage bags for clean up. Bring everything you'll need. No borrowing!

**INSTRUCTIONS:** The skill stations will be shut down for lunch at about 11:55 AM, at which time all Patrols must stay at their last skill station which becomes their cooking site. Patrols will have a cooking location at the station assigned by the judge. All cooking will start at 12:00 noon and Patrols must start fires in their hobo stoves. All food must be prepared and cooked at the lunch site. Prepare the meal, eat and completely clean up and stow all gear in one hour. Patrols not finished in the one-hour time limit will have pints deducted from their score.

**ADDITIONAL EQUIPMENT:** Each Patrol will need to bring a hobo stove of the type shown. The Patrols must also bring enough charcoal or dry wood to cook the meal. Fire starters are recommended.

Secure a five-gallon metal bucket. It may be round or square. Burn it out well to get rid of whatever was in it, such as paint, detergent, tar, etc.

Cut holes near the bottom of the can. They must be at least 4 X 4 inches. Let at least a 3-inch wide strip of metal between the holes as shown in the drawing.

The stove needs a lid on which to set your cooking utensils and allow smoke to escape. Make this from ½ inch mesh chicken wire, fastened on a heavy wire hoop. The hoop should be about an inch larger in diameter than the top of the hobo stove.

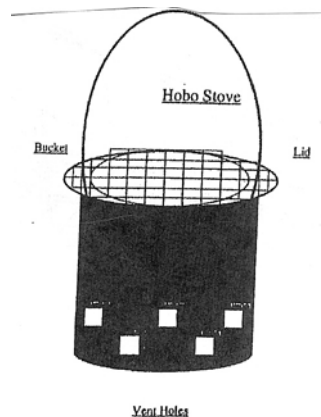

2010 APPALACHIAN  
KLONDIKE DERBY  
**TROOP ROSTER**

Troop # \_\_\_\_\_

Unit Leader: \_\_\_\_\_

Sr. Patrol Leader: \_\_\_\_\_

Patrol Name:

\_\_\_\_\_

Scouts:

\_\_\_\_\_  
\_\_\_\_\_  
\_\_\_\_\_  
\_\_\_\_\_  
\_\_\_\_\_  
\_\_\_\_\_  
\_\_\_\_\_

Patrol Name:

\_\_\_\_\_

Scouts:

\_\_\_\_\_  
\_\_\_\_\_  
\_\_\_\_\_  
\_\_\_\_\_  
\_\_\_\_\_  
\_\_\_\_\_  
\_\_\_\_\_

Adult Leader: \_\_\_\_\_

Adult Leader: \_\_\_\_\_

Adult Leader: \_\_\_\_\_

Adult Leader: \_\_\_\_\_

Patrol Name:

\_\_\_\_\_

Scouts:

\_\_\_\_\_  
\_\_\_\_\_  
\_\_\_\_\_  
\_\_\_\_\_  
\_\_\_\_\_  
\_\_\_\_\_  
\_\_\_\_\_

Patrol Name:

\_\_\_\_\_

Scouts:

\_\_\_\_\_  
\_\_\_\_\_  
\_\_\_\_\_  
\_\_\_\_\_  
\_\_\_\_\_  
\_\_\_\_\_  
\_\_\_\_\_

Adult Leader: \_\_\_\_\_

Adult Leader: \_\_\_\_\_

Adult Leader: \_\_\_\_\_

Adult Leader: \_\_\_\_\_

# APPALACHIAN DISTRICT BOY SCOUT KLONDIKE DERBY

Troop Registration Form  
January 16, 2010  
8:00 AM to 4:00 PM  
Rain, Snow or Shine

Return this form to: Hawk Mountain Council, BSA  
- 5027 Pottsville Pike, Reading, PA 19605

Troop # \_\_\_\_\_ will enter  
\_\_\_\_\_ patrols.

PATROL NAME  
\_\_\_\_\_  
Number of Scouts \_\_\_\_\_

PATROL NAME  
\_\_\_\_\_  
Number of Scouts \_\_\_\_\_

PATROL NAME  
\_\_\_\_\_  
Number of Scouts \_\_\_\_\_

PATROL NAME  
\_\_\_\_\_  
Number of Scouts \_\_\_\_\_

PATROL NAME  
\_\_\_\_\_  
Number of Scouts \_\_\_\_\_

PATROL NAME  
\_\_\_\_\_  
Number of Scouts \_\_\_\_\_

Please register \_\_\_\_\_ total Boy Scouts at \$5.00  
each = \$ \_\_\_\_\_

Please register \_\_\_\_\_ total Adult Leaders at  
\$5.00 each = \$ \_\_\_\_\_

Fees Submitted = \$ \_\_\_\_\_ Total

\* The fee includes: patch, hot dog, hot chocolate,  
insurance and camp fees.

TROOP NUMBER \_\_\_\_\_

Payment may be made by one of the following:

\_\_\_\_\_ (cash) \_\_\_\_\_ (check) Make  
checks payable to: **Hawk Mountain Council**

\_\_\_\_\_ (charge unit account) **Unit Number** \_\_\_\_\_

\_\_\_\_\_ (credit card) MasterCard, Visa or Discover

Name as it appears on card: \_\_\_\_\_

Address \_\_\_\_\_  
\_\_\_\_\_

Credit Card Number: \_\_\_\_\_

Expiration Date: \_\_\_\_\_

3 digit code on back of card \_\_\_\_\_

Leader \_\_\_\_\_

Phone # \_\_\_\_\_

E-mail \_\_\_\_\_

*Registrations received after January 8, 2010 will be an extra  
\$1.00 per Scout or Adult Leader. .*